

INSTALLATION INSTRUCTIONS

DESCRIPTION: Front Brush Guard Kit
PART NUMBER: B5K-F84L0-V0
MODEL: Kodiak 700



⚠ WARNING

Please read and understand these instructions completely before installation to avoid possible injury, or damage to the accessory or vehicle.

WARRANTY INFORMATION:

Genuine Yamaha Accessories are covered by a one-year limited warranty against defects in material or workmanship. Labor for replacement of defective components is not covered. See your Yamaha dealer for a copy of the warranty statement.

NOTICES:

This installation requires a torque wrench and should be performed by an authorized Yamaha dealer or other qualified technician.

DEALER OR INSTALLER:

These instructions contain important information for future reference and *must* be given to the customer.

PARTS LIST:

No.	Part Number	Description	Qty
--	B5K-F84L0-V0	Front Brush Guard Kit	--
①	*	Front Brush Guard	1

* Part supplied with kit only and not available separately.

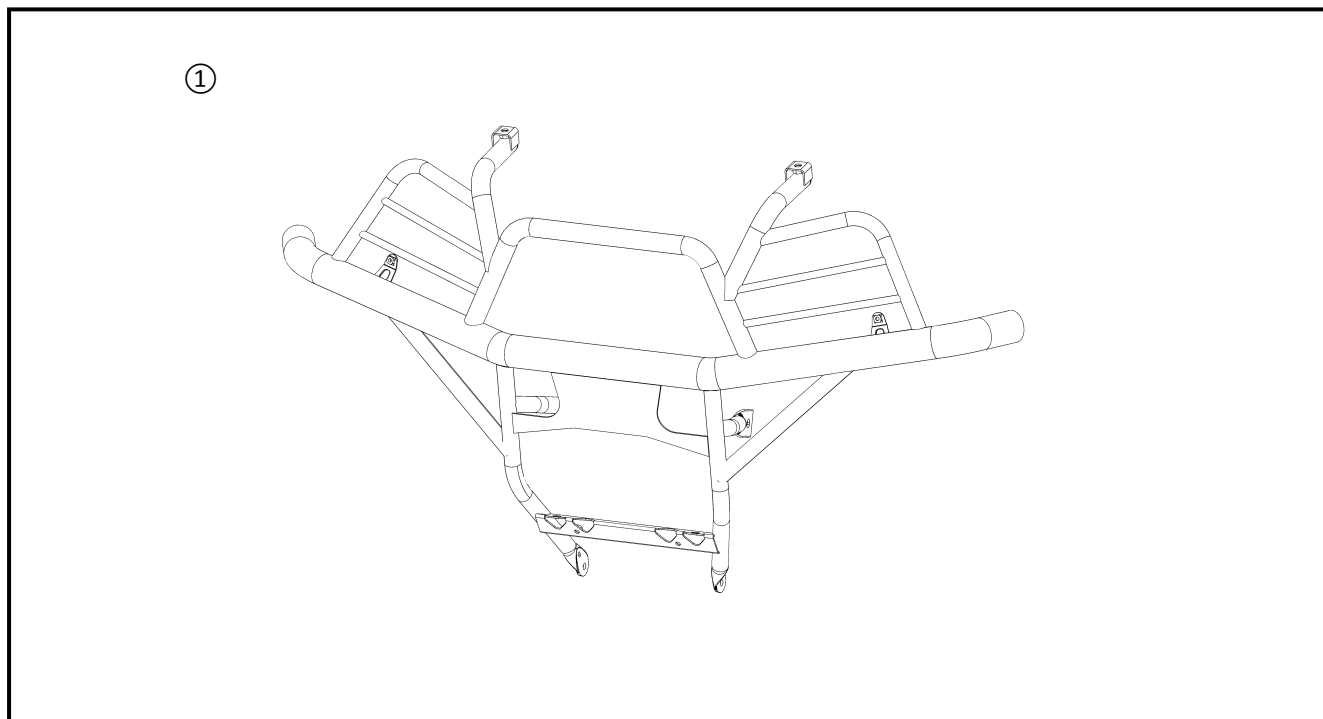

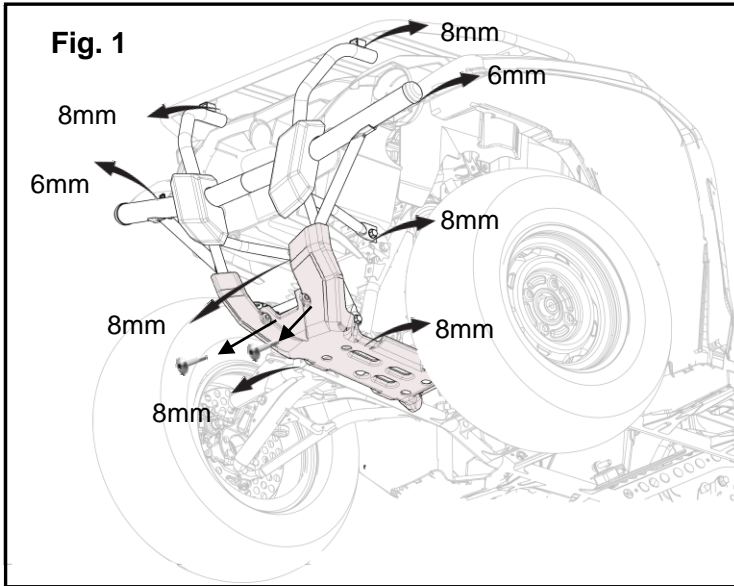

Fig. 1

PREPARATION:

- Place the vehicle on a secure and level surface.
- Set the parking brake.
- Clean the mount surfaces before starting installation.

INSTALLATION:

1. Remove the 2 bolts that retain the front edge of the stock plastic bash plate. Let the front edge of the bash plate drop down. Retain the two bolts for reuse (Fig. 1).
2. Remove the 4 bolts on the left and 4 bolts on the right that hold the stock grab bar to the vehicle. There are six 8mm bolts and two 6mm bolts as shown in Fig.1. Retain these bolts for reuse. Remove the stock front grab bar. It will not be reused.
3. Install the ① Front Brush Guard using stock mount locations and reuse the stock 8mm and 6mm bolts. Fig. 2 shows the locations of the left side mount locations.
4. Install the bolts hand tight to allow for some adjustment. The right side is a mirror image of the left, in this installation.
5. Torque the 8mm bolts to 34 Nm (3.4 M-kgf, 24 ft-lbf) as shown in Fig. 2. Torque the 6mm bolts to 3Nm (0.3 M-kgf, 2.2 ft-lbf).

Note: The 6mm bolts thread into spring nuts. The spring nuts may shift position during the removal of the stock grab bar. Adjust the position of the spring nut as needed.

6. Install the front of the skid plate to the mount points using the stock bolts. Torque the bolts to 7Nm (0.7 m-kgf, 5.1 ft-lbf). Refer to Fig. 3.

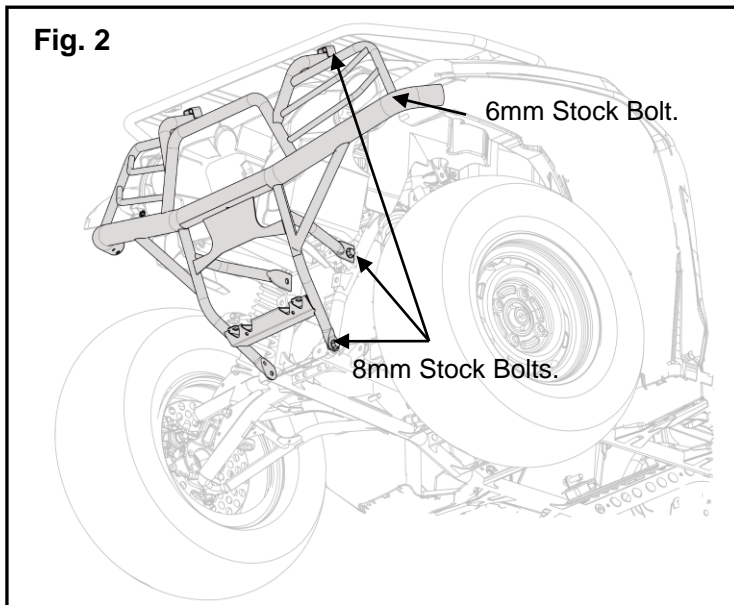

Fig. 2

MAINTENANCE:

Periodically, check torque on all hardware. If loose hardware is found, re-torque to specification.

CARE AND CLEANING:

Clean painted metal parts with a clean soft cloth and mild soap and water. Rinse and dry. Clean the windscreen with a clean soft cloth and mild soap and water solution.

CUSTOMER SERVICE:

For further information see your Yamaha dealer.

ESTIMATED TIME TO INSTALL: 1.0 HRS

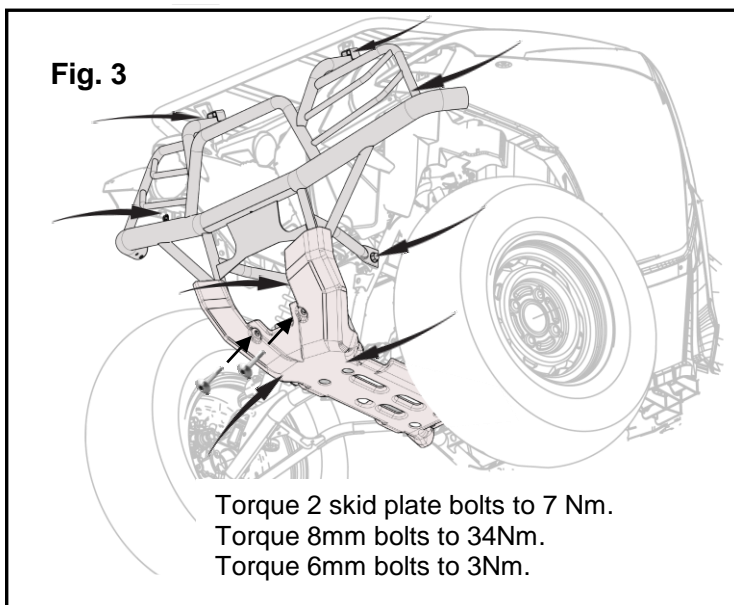

Fig. 3

Torque 2 skid plate bolts to 7 Nm.
 Torque 8mm bolts to 34Nm.
 Torque 6mm bolts to 3Nm.